

# Tensile Test

## OBJECTIVES

- Students are required to understand the principle of a uniaxial tensile testing and gain their practices on operating the tensile testing machine to achieve the required tensile properties.
- Students are able to explain load-extension and stress-strain relationships and represent them in graphical forms.
- To evaluate the values of ultimate tensile strength, yield strength, % elongation, fracture strain and Young's Modulus of the selected metals when subjected to uniaxial tensile loading.
- Students can explain deformation and fracture characteristics of different materials such as aluminum, steels or brass when subjected to uniaxial tensile loading.

## UNIAXIAL TENSILE TESTING

Uniaxial tensile test is known as a basic and universal engineering test to achieve material parameters such as ultimate strength, yield strength, % elongation, % reduction of area and Young's modulus. These important parameters obtained from the standard tensile testing are useful for the selection of engineering materials for any applications required.

The tensile testing is carried out by applying longitudinal or axial load at a specific extension rate to a standard tensile specimen with known dimensions (gauge length and cross sectional area perpendicular to the load direction) till failure. The applied tensile load and extension are recorded during the test for the calculation of stress and strain. A range of universal standards provided by Professional societies such as American Society of Testing and Materials (ASTM), British standard, JIS standard and DIN standard (*Deutsches Institut für Normung*, the German Institute for Standardization)

مختبر مقاومة المواد

المرحلة الثانية

تجربة  
(1)

provides testing are selected based on preferential uses. Each standard may contain a variety of test standards suitable for different materials, dimensions and fabrication history. For instance, ASTM E8: is a standard test method for tension testing of metallic materials and ASTM B557 is standard test methods of tension testing wrought and cast aluminum and magnesium alloy products.

A standard specimen is prepared in a round or a rectangular section along the gauge length as shown in figures 1 a) and b) respectively, depending on the standard used. Both ends of the specimens should have sufficient length and a surface condition such that they are firmly gripped during testing. The initial gauge length  $L_0$  is standardized and varies with the diameter ( $D_0$ ) or the cross-sectional area ( $A_0$ ) of the specimen as listed in Table 1. This is because if the gauge length is too long, the % elongation might be underestimated in this case.

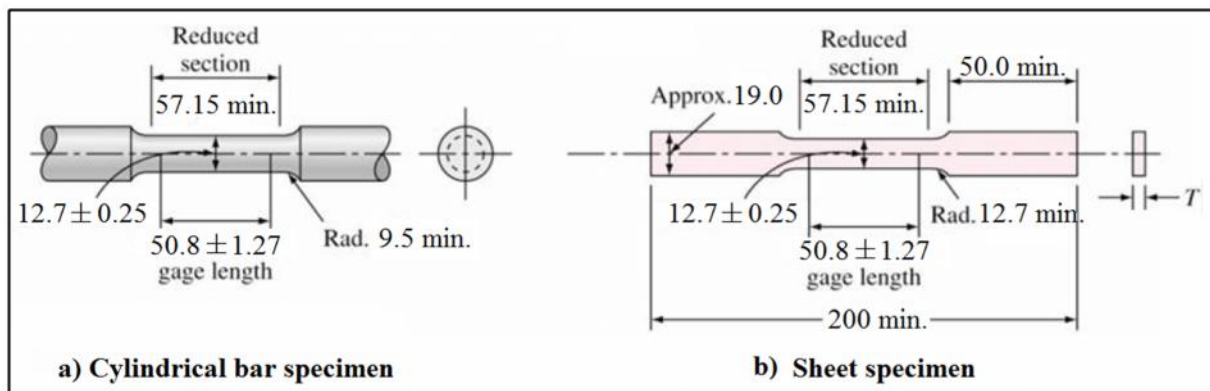

Figure 1: Standard tensile specimens

Table 1: Dimensional relationships of different standard specimens.

Type specimen	ASTM	JIS	DIN
Sheet $L_0 / \sqrt{A_0}$	4.5	5.65	11.3
Rod $L_0 / D_0$	4.0	5.0	10.0

## UNIVERSAL TESTING MACHINES

The equipment used for tensile testing ranges from simple devices to complicated controlled systems. The so-called universal testing machines are commonly used, which are driven by mechanical screw or hydraulic systems.

Figure 2 shows the universal test machine available at our lab, which is Tinius Olsen T-series. The T-series machines communicate directly with a standard PC under MS-Windows based data analysis software packages, via a high speed RS232 in both ASCII and super high speed binary modes. This type of machine can be used not only for tension, but also for compression and bending. Most of the machines used nowadays are linked to a computer-controlled system in which the load and extension data can be graphically displayed together with the calculations of stress and strain.

General techniques utilized for measuring loads and displacements employs sensors providing electrical signals. Load cells are used for measuring the load applied while strain gauges are used for strain measurement. A Change in a linear dimension is proportional to the change in electrical voltage of the strain gauge attached on to the specimen.



**Figure 2:** Tinius Olsen T-series universal test machine.

### **STRESS AND STRAIN RELATIONSHIP**

When a specimen is subjected to an external tensile loading, the metal will undergo elastic and plastic deformation. Initially, the metal will elastically deform giving a linear relationship of load and extension. These two parameters are then used for the calculation of the engineering stress and engineering strain to give a relationship as illustrated in Figure 3 using equations 1 and 2 as follows

where  $\sigma$  is the engineering stress

$\varepsilon$  is the engineering strain

$P$  is the external axial tensile load

$A_o$  is the original cross-sectional area of the specimen

$L_o$  is the original length of the specimen

$L_f$  is the final length of the specimen

The unit of the engineering stress is Pascal (Pa) or  $N/m^2$  (SI Metric Unit).

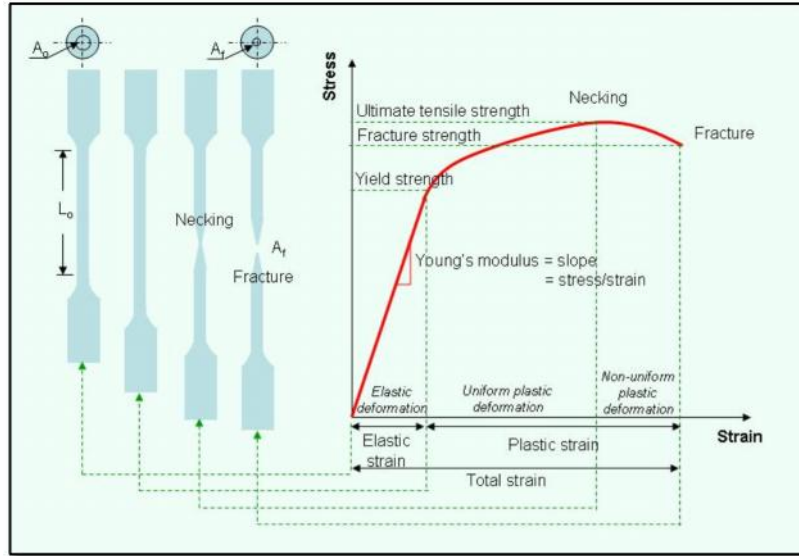

**Figure 3:** Stress-strain relationship under uniaxial tensile loading

During elastic deformation, the engineering stress-strain relationship follows the Hooke's Law and the slope of the curve indicates the modulus of elasticity or Young's modulus ( $E$ ).

Young's modulus is of importance where deflection of materials is critical for the required engineering applications. This is for examples: deflection in structural beams is considered to be crucial for the design in engineering components or structures such as *bridges, building, ships*, etc. The applications of *tennis racket* and *golf club* also require specific values of spring constants or Young's modulus values.

By considering the stress-strain curve beyond the elastic portion, if the tensile loading continues, yielding occurs at the beginning of plastic deformation. The yield stress,  $\sigma_y$ , can be obtained by dividing the load at yielding ( $P_y$ ) by the original cross-sectional area of the specimen ( $A_o$ ) as shown in equation 4.

The yield point can be observed directly from the load-extension curve of the BCC metals such as iron, steel and especially low carbon steels, see Figure 4a. The yield point elongation phenomenon shows the upper yield point followed by a sudden reduction in the stress or load till reaching the lower yield point.

Aluminum on the other hand having a FCC crystal structure does not show the definite yield point (Figure 4b) in comparison to those of the BCC structure materials, but shows a smooth engineering stress-strain curve. The yield strength therefore has to be calculated from the load at 0.2% strain divided by the original cross-sectional area as follows

The determination of the yield strength at 0.2% offset or 0.2% strain can be carried out by drawing a straight line parallel to the slope of the stress-strain curve in the linear section, having an intersection on the  $x$ -axis at a strain equal to 0.002 (as illustrated in Figure 4b). An interception between the 0.2% offset line and the stress-strain curve represents the yield strength at 0.2% offset or 0.2% strain.

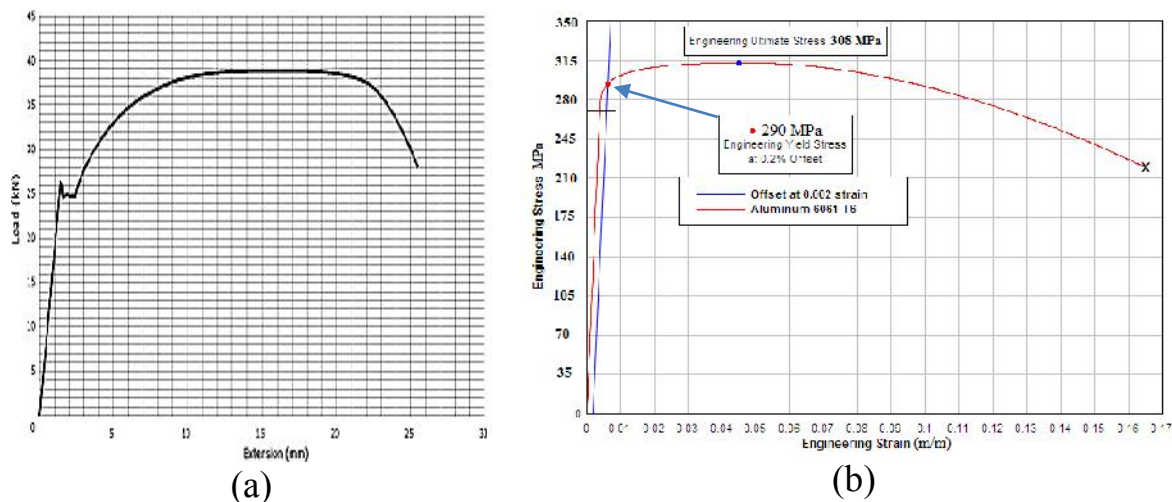

**Figure 4:** (a) stress-strain relationships of low carbon steel, (b) the determination of the yield strength at 0.2% offset for aluminum alloy.

Beyond yielding, continuous loading leads to an increase in the stress required to permanently deform the specimen as shown in the engineering stress-strain curve. At this stage, the specimen is strain hardened or work hardened. The degree of strain hardening depends on the nature of the deformed materials, crystal structure and chemical composition, which affects the dislocation motion. FCC structure materials having a high number of operating slip systems can easily slip and create a high density of dislocations. Tangling of these dislocations requires higher stress to uniformly and plastically deform the specimen, therefore resulting in strain hardening.

If the load is continuously applied, the stress-strain curve will reach the maximum point, which is the ultimate tensile strength (UTS,  $\sigma_u$ ). At this point, the specimen can withstand the highest stress before necking takes place. This can be observed by a local reduction in the crosssectional area of the specimen generally observed in the center of the gauge length.

Tensile ductility of the specimen can be represented as % elongation or % reduction in area as expressed in the equations given below

where  $A_f$  is the cross-sectional area of specimen at fracture.

The fracture strain of the specimen can be obtained by drawing a straight line starting at the fracture point of the stress-strain curve parallel to the slope in the linear relation. The interception of the parallel line at the  $x$ -axis indicates the fracture strain of the specimen being tested.

## FRACTURE CHARACTERISTICS OF THE TESTED SPECIMENS

Metals with good ductility normally exhibit a so-called *cup and cone fracture* characteristic observed on either halves of a broken specimen as illustrated in Figure 5. Necking starts when the stress-strain curve has passed the maximum point where plastic deformation is no longer uniform. Across the necking area within the specimen gauge length (normally located in the middle), microvoids are formed, enlarged and then merged to each other as the load is increased. This creates a crack having a plane perpendicular to the applied tensile stress. Just before the specimen breaks, the shear plane of approximately  $45^\circ$  to the tensile axis is formed along the peripheral of the specimen. This shear plane then joins with the former crack to generate the cup and cone fracture as demonstrated in Figure 5. The rough or fibrous fracture surfaces appear in grey by naked eyes. Under *scanning electron microscope* (SEM), copious amounts of micro-voids are observed as depicted in Figure 6a. This type of fracture surface signifies high energy absorption during the fracture process due to large amount of plastic deformation taking place, also indicating good tensile ductility. Metals such as aluminum and copper normally exhibit ductile fracture behavior due to a high number of slip systems available for plastic deformation.

For brittle metals or metals that failed at relatively low temperatures, the fracture surfaces usually appear bright and consist of flat areas of brittle facets when examined under SEM as illustrated in Figure 6b. In some cases, clusters of these brittle facets are visible when the grain size of the metal is sufficiently large. The energy absorption is quite small in this case which indicates relatively low tensile ductility due to limited amount of plastic deformation prior to failure.



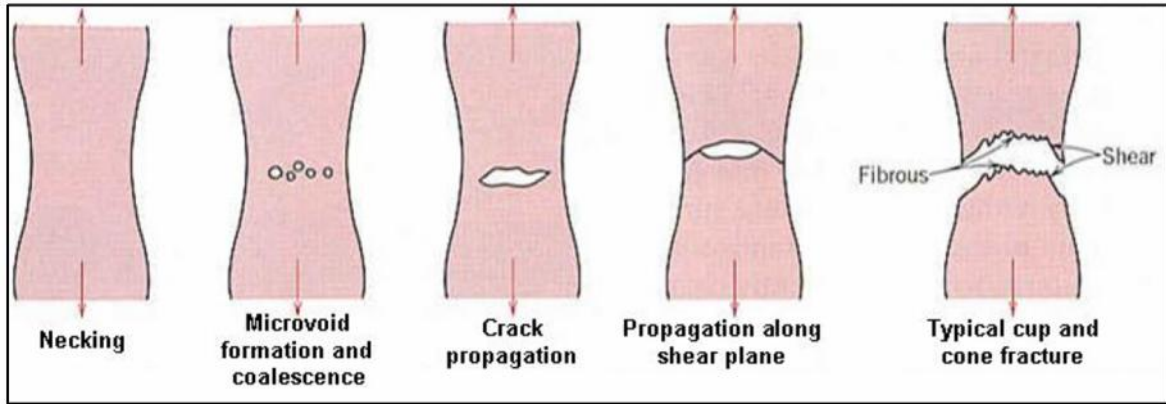

Figure 5: Cup and cone fracture

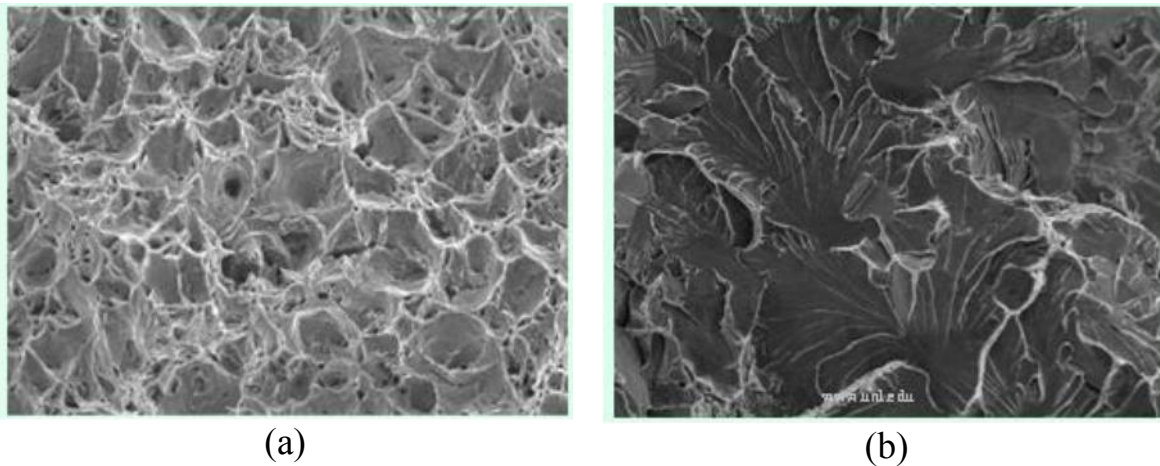

Figure 6: (a) Ductile fracture surface (Ductile metals), (b) Brittle fracture surface (Brittle metals)

#### EXPERIMENTAL PROCEDURE

- The specimens provided are made of steel or aluminum. Measure and record specimen dimensions (diameter and gauge length) in a table provided for the calculation of the engineering stress and engineering strain. Marking the location of the gauge length along the parallel length of each specimen for subsequent observation of necking and strain measurement.
- Fit the specimen on to the Universal Testing Machine (UTM) and carry on testing. Record load and extension for the construction of stress-strain curve of each tested specimen.

# Torsion Test

## OBJECTIVES

- To understand the principles of torsion testing, practice their testing skills and interpreting the experimental results of the provided materials when failed under torsion.
- To determine the maximum shearing stress, shear stress at proportional limit, shear modulus or modulus of rigidity and relationships between torque and degree of rotation of the tested materials.
- To differentiate the ability of materials such as cast iron and brass to withstand torque prior to torsion failure. Analysis and interpretation of the test parameters obtained should be carried out in relation to the failure nature of each material.
- Selecting materials for engineering applications associated with torsion.

## MATERIALS

Mild Steel rod ( $d$  mm) diameter over  $L_0$  mm length (overall length including hexagon ends =  $L_2$  mm) as shown in Figure 1.

مختبر مقاومة المواد

المرحلة الثانية

تجربة  
(2)

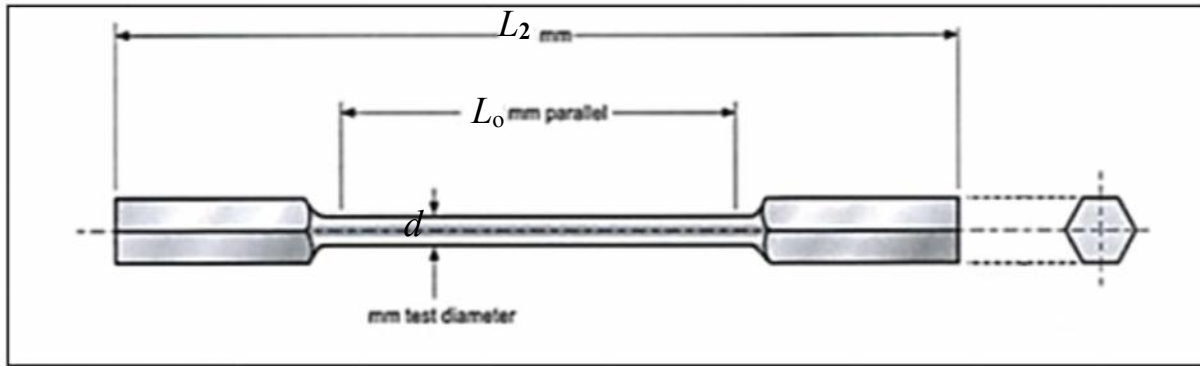

**Figure 1:** Torsion specimen

### APPLICATIONS

In many areas of engineering applications, materials are, sometimes, subjected to torsion in services, for example, drive shafts, axles and twisted drills. Moreover, structural applications such as bridges, springs, car bodies, airplane fuselages and boat hulls are randomly subjected to torsion. The materials used in this case should require not only adequate strength but also be able to withstand torque in operation.

### THEORY

Generally, torsion occurs when the twisting moment or torque is applied to a member according to Figure 2. The torque is the product of tangential force multiplied by the radial distance from the twisting axis and the tangent, measured in a unit of N.m. In torsion testing, the relationship between torque and degree of rotation is graphically presented and parameters such as ultimate torsional shearing strength (modulus of rupture), shear strength at proportional limit and shear modulus (modulus of rigidity) are generally investigated. Moreover, fracture surfaces of specimens tested under torsion can be used to determine the characteristics of the materials whether it would fail in a brittle or a ductile manner.

In order to study the response of materials under a torsional force, the torsion test is performed by mounting the specimen onto a torsion testing machine as shown in Figure 3, and then applying the twisting moment till failure.

The torque and degree of rotation are measured. It can be seen that higher torsional force is required at the higher degrees of rotation. Normally, the test specimens used are of a cylindrical rod type since the stress distribution across the section of the rod is the simplest geometry, which is easy for the calculation of the stresses. Both ends of the cylindrical specimen are tightened to hexagonal sockets in which one is fitted to a torque shaft and another is fitted to an input shaft.

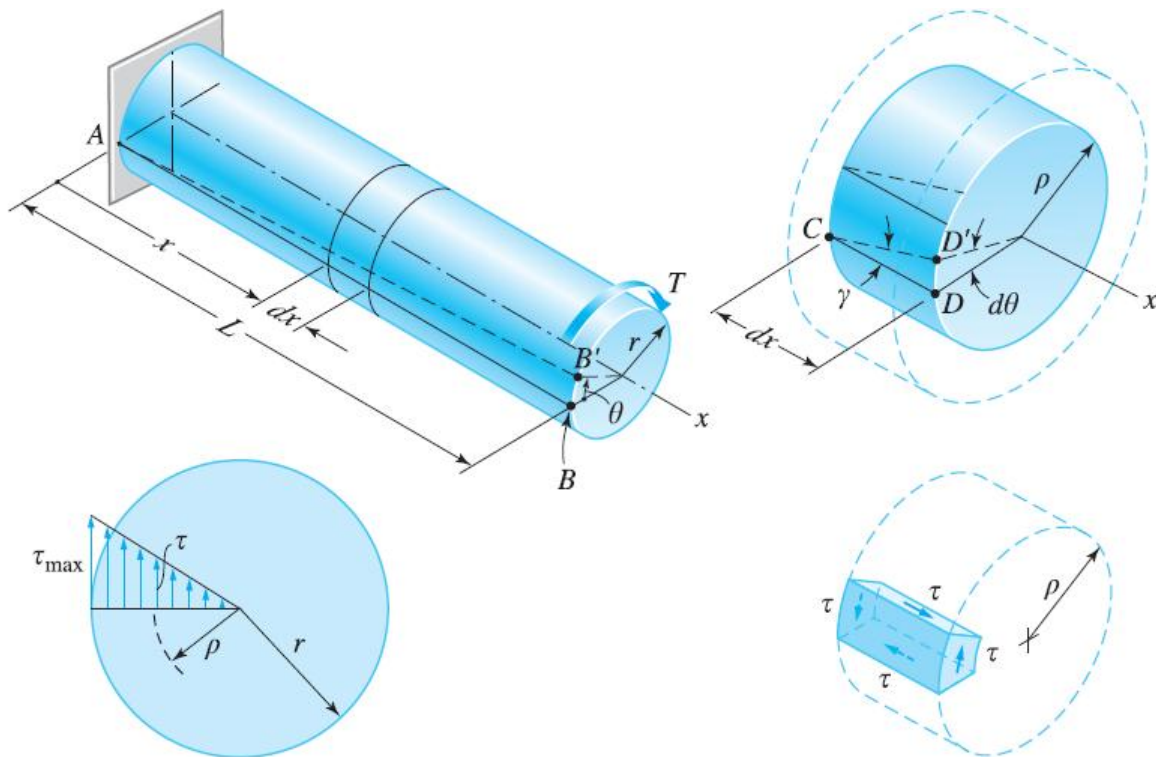

**Figure 2:** Torsion in cylindrical bar



**Figure 3:** Torsion testing machine

# Thick Cylinder Test

## OBJECTIVES

The purpose of this experiment is to obtain the radial strain, radial stress and tangential stress in a thick walled cylinder subjected to internal pressure.

## INTRODUCTION

Cylindrical pressure vessels are used in industry as tanks, boilers or containers as shown in Figure 1. When under pressure the material is subjected to loadings in all directions.



**Figure 1:** Thick cylinder pressure vessels (tank).

In general, pressure vessel may be thin or thick. It can recognize between them according to the ratio between thicknesses to diameter of vessel ( $t/d$ ):

- If  $(t/d) < 0.05 \Rightarrow$  *thin cylinder*
- If  $(t/d) \geq 0.05 \Rightarrow$  *thick cylinder*

مختبر مقاومة المواد

المرحلة الثانية

تجربة  
(3)



### APPARATUS DESCRIPTION

TecQuipment's Thick Cylinder apparatus, shown in Figure 2, allows students to examine radial and hoop stresses and strains in the wall of a thick cylinder. They can then compare experiment results with the theoretical Lamé predictions. It clearly shows the principles, theories and analytical techniques, and provides effective, practical support to studies.

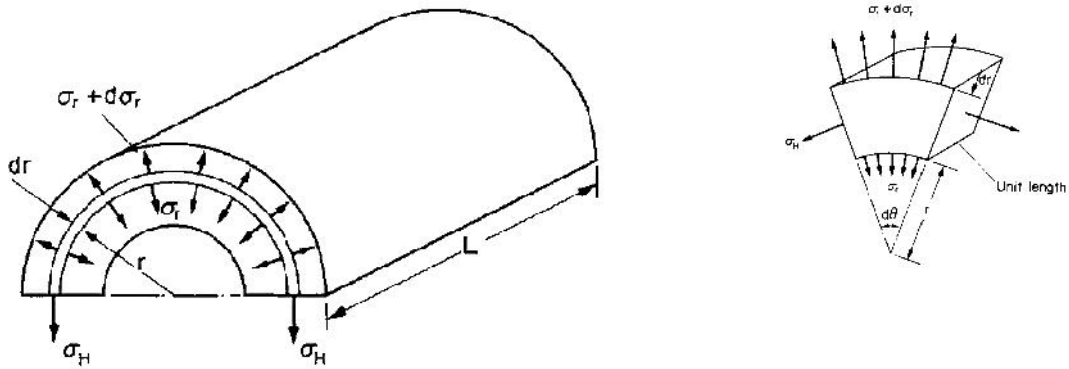
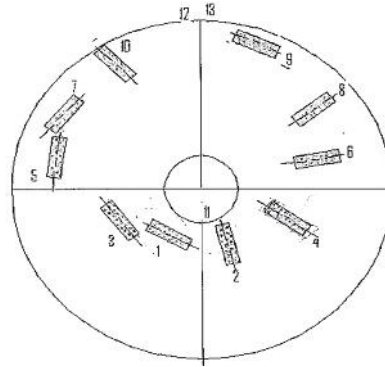

**Figure 2:** TecQuipment's Thick Cylinder apparatus

The apparatus consists of a thick-walled aluminum cylinder, held in a robust frame. The cylinder is in two halves, cemented together. One face of the joint has an eccentric shallow groove that contains ten strain gauges at precise radii and orientation, Figure 3. These gauges measure the radial and hoop strains. Jointing cement fills the groove. Strain gauges on the inner and outer walls of the cylinder measure longitudinal and circumferential strains. The cylinder contains oil. To stress the cylinder, students use a hydraulic hand-pump to pressurize the oil. To perform experiments, students set the gauges to zero and use the pump to pressurize the cylinder. They take readings at several stages while increasing the pressure. The results can be taken by hand using the in-built display and pressure

gauge and plotted by hand. They then compare their results with calculations made using theory.

**Figure 3:** Strain gages locations.



**Figure 4:** Stresses in a thick cylinder



# Fatigue Test

## OBJECTIVES

Know why the metals fail when exposed to stress less than the yield stress or tensile stress when subjected to cycling loading, or to investigate the failure of metals due to fatigue loading.

## INTRODUCTION

Fatigue analysis, as we know it today, has come a long way. 170 years ago, in 1837, Wilhelm Albert published the first article on fatigue, establishing a correlation between applied loads and durability. Two years later, in 1839, Jean-Victor Poncelet, designer of cast iron axles for mill wheels as shown in Figure 1, officially used the term "fatigue" for the first time in a book on mechanics.

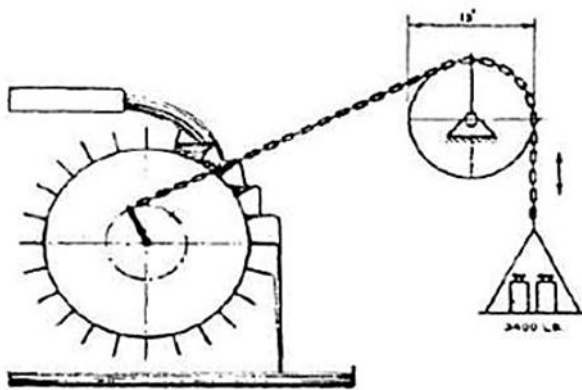

**Figure 1:** Albert's fatigue tests of mining chains, sketch

In materials science, fatigue is the weakening of a material caused by repeatedly applied loads. It is the progressive and localized structural damage that occurs when a material is subjected to cyclic loading. The nominal maximum stress values that cause such damage may be much less than the ultimate tensile stress limit, or the yield stress limit.

مختبر مقاومة المواد

المرحلة الثانية

تجربة  
(4)

## **FATIGUE**

Fatigue occurs when a material is subjected to repeat loading and unloading. If the loads are above a certain threshold, microscopic cracks will begin to form at the stress concentrators such as the surface, persistent slip bands (PSBs), and grain interfaces. Eventually a crack will reach a critical size, the crack will propagate suddenly, and the structure will fracture. The shape of the structure will significantly affect the fatigue life; square holes or sharp corners will lead to elevated local stresses where fatigue cracks can initiate. Round holes and smooth transitions or fillets will therefore increase the fatigue strength of the structure.

## **FATIGUE LIFE $N$**

Number of stress cycles of a specified character that a specimen sustains before failure of a specified nature occurs.

## **BACKGROUND**

Fatigue is the condition where by a material cracks or fails as a result of repeated (cyclic) stresses applied below the ultimate strength of the material.

Fatigue failures generally involve three stages:

1. Crack Initiation,
2. Crack Propagation, and
3. Fast Fracture

Fatigue failures often occur quite suddenly with catastrophic (disastrous) results and although most insidious for metals, polymers and ceramics (except for glasses) are also susceptible to sudden fatigue failures. Fatigue causes brittle like failures even in normally ductile materials with little gross plastic deformation occurring prior to fracture. The process occurs by the initiation and propagation of cracks and, ordinarily, the fracture surface is close to perpendicular to the direction of maximum tensile stress.

Applied stresses may be axial (tension-compression), flexural (bending) or torsional (twisting) in nature. In general, there are three possible fluctuating stress-time modes possible. The simplest is completely reversed constant amplitude where the alternating stress varies from a maximum tensile stress to a minimum compressive stress of equal magnitude. The second type, termed repeated constant amplitude, occurs when the maxima and minima are asymmetrical relative to the zero stress level. Lastly, the stress level may vary randomly in amplitude and frequency which is merely termed random cycling. Figure 2 shows a schematic that illustrating the cyclic loading fatigue parameters, tensile stresses are normally considered positive and compressive stresses are considered negative.

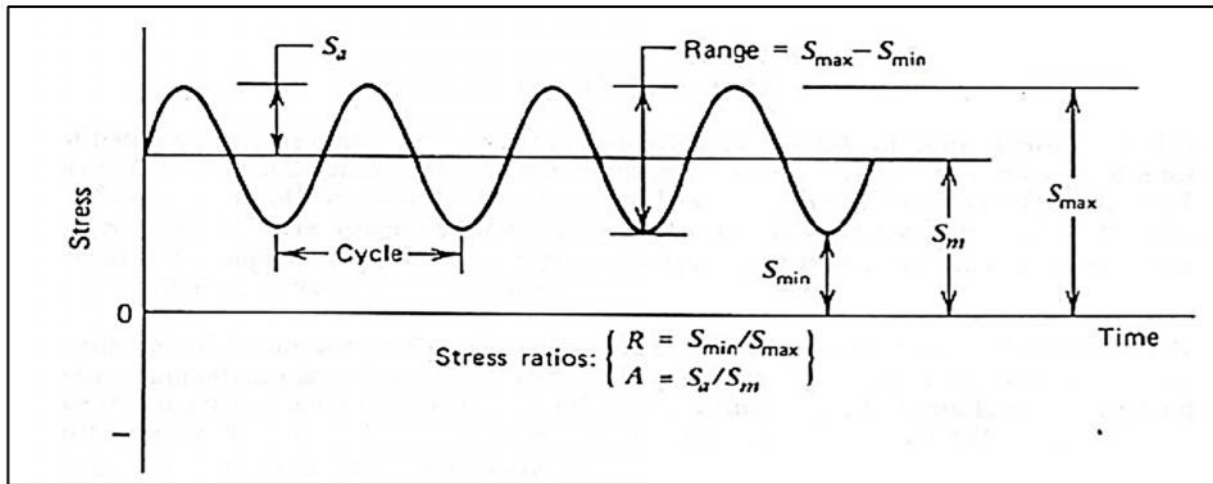
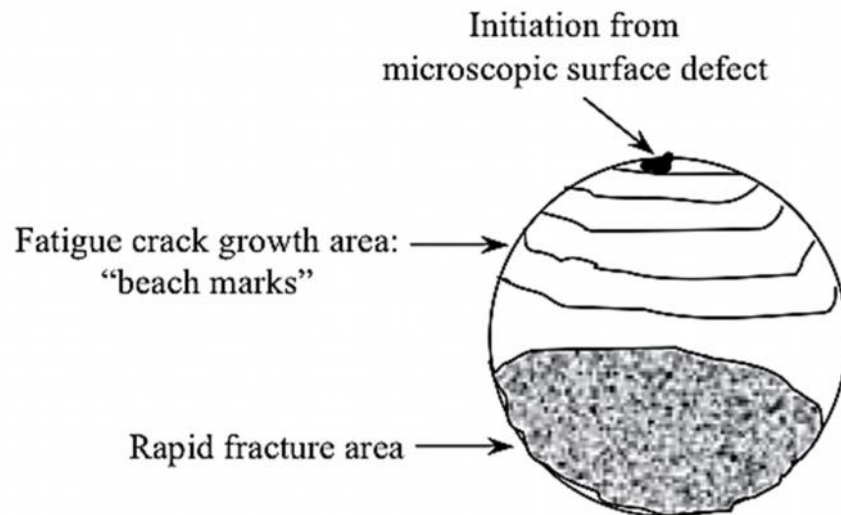

**Figure 2:** Schematic Illustrating Cyclic Loading Parameters

The following parameters are utilized to identify fluctuating stress cycles:

The *Fatigue Life* ( $N_f$ ) of a component is defined by the total number of stress cycles required to cause failure. Fatigue life can be separated into three stages (as shown in Figure 3) where

- **Crack Initiation ( $N_i$ )** - Cycles required to initiate a crack. Generally results from dislocation pile-ups and/or imperfections such as surface scratches, voids, etc.
- **Crack Growth ( $N_p$ )** - Cycles required to grow the crack in a stable manner to a critical size. Generally controlled by stress level. Since most common materials contain flaws, the prediction of crack growth is the most studied aspect of fatigue.
- **Rapid Fracture-** Very rapid critical crack growth occurs when the crack length reaches a critical value,  $a_c$ . Since Rapid Fracture occurs quickly, there is no Rapid Fracture term in the Fatigue Life expression.

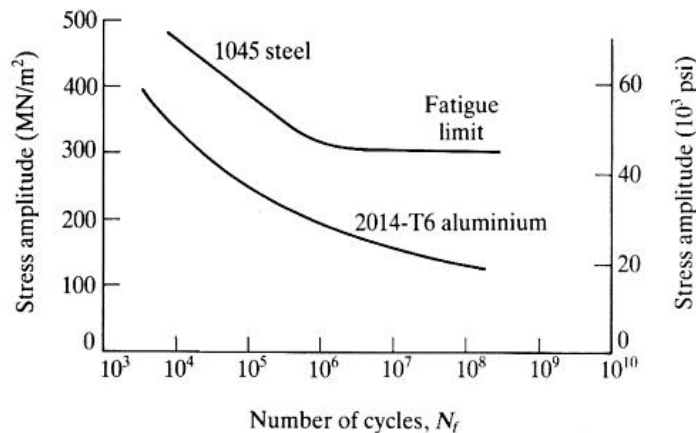

**Figure 3:** Rail shaft shows the three stages of fatigue failure

**$S-N_f$  CURVE**

Most Fatigue Tests are conducted at what is referred to as “Constant Amplitude” which merely refers to the fact that the maximum and minimum stresses are constant for each cycle of a test.  $S-N_f$  refers to a plot of *Constant Amplitude Stress Level (S)* versus *Number of Cycles to Failure ( $N_f$ )*.  $S-N_f$  Curves are generally plotted on semi-log or log-log paper where each dot represents the results of a single test specimen. Fatigue tests tend to be time consuming and expensive; each data point represents many hours of testing.

A prediction of failure for various stress levels can be made by studying a material’s  $S-N_f$  curve. The most important part of the curve is often the portion to the right of the bend (or “knee”) in the curve that identifies what is termed the **Endurance Limit** or the **Fatigue Limit** (Figure 4). The Endurance Limit defines the *stress level below which the material will theoretically withstand an infinite number ( $10^7$ ) of stress cycles without fracture*.

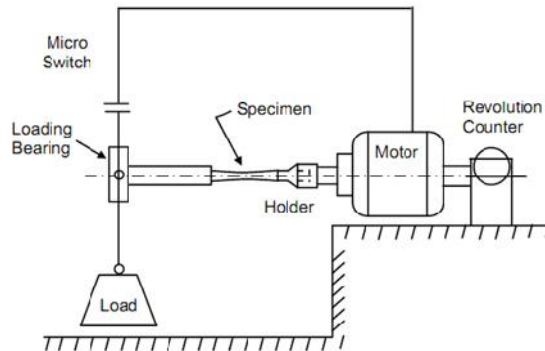

**Figure 4:** Stress Amplitude versus Number of Cycles to Failure Curves

### FATIGUE TESTING

Materials Testing to obtain  $S-N_f$  Curves is common; several ASTM standards address stress-based fatigue testing.

- **Rotating Bending Testing Machine** is similar to the original railroad axle-type Wohler used where the bending moment is constant along the beam length. Each point on the Surface of the Rotating Bend Specimen is subjected to fully-reversed cycling ( $\sigma_m = 0$ ) and the tests are generally Constant Amplitude as shown in Figure 5.
- **Reciprocating Bending Testing Machines** utilize a rotating crank to achieve a non-zero mean stress through positioning of the specimen with respect to the motor as shown in Figure 6.
- **Direct Force Fatigue Testing Machines** apply axial loads as is illustrated in Figure 7.



**Figure 5: Rotating Bending Testing Machine**

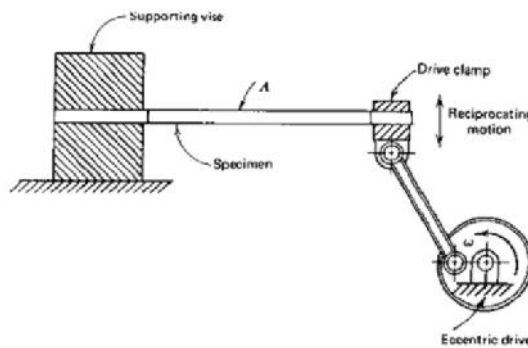

**Figure 6: Reciprocating Bending Testing Machine**

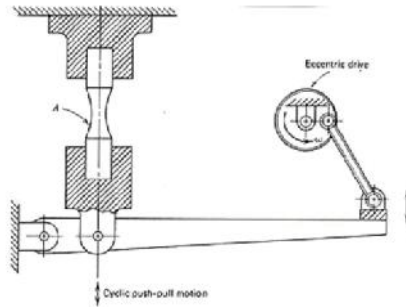

**Figure 7:** Direct-Force Fatigue Testing Machine

### EXPERIMENTAL PROCEDURE

1. Measure the dimensions of specimen as shown in Figure 8 provided and record in Table 1. If the distance from the load end to the minimum diameter of the specimen is 125.7 mm, the bending stress,  $\sigma$ , can be calculated the bending stress for a load  $P$  (N) as:
2. Conduct the fatigue test at room temperature using the fatigue testing machine as shown in Figure 9. Fit one end of the specimen to a motor and fit the other end to a bearing hung with a known weight, indicating the stress applied to the specimen. Start the motor to rotate the specimen at a constant speed. The revolution counter is used to record the number of cycles to which the specimen fails. Record the result in Table 1.
3. Change the weights used, record the results in Table 1.
4. Draw the  $S-N$  curves of the steel specimens.
5. Investigate fracture surfaces of broken fatigue specimen.
6. Analyze, discuss the obtained results. Give conclusions.

**Table 1:** Test results recording

No.	D (mm)	P (N)	Max. Stress ( $\frac{P}{A}$ ) ( $N/mm^2$ ) $\sigma_{max}$	Number of Cycles N (Cycle)
1				
2				
3				
4				

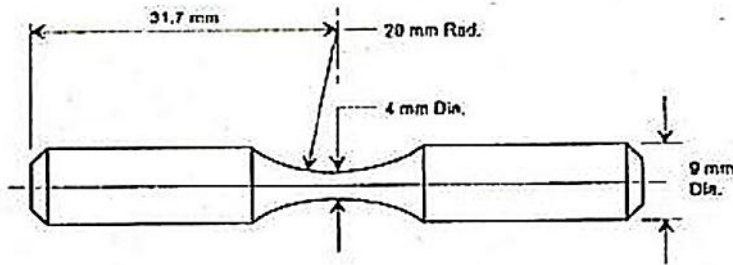

**Figure 8:** Fatigue specimen dimensions.

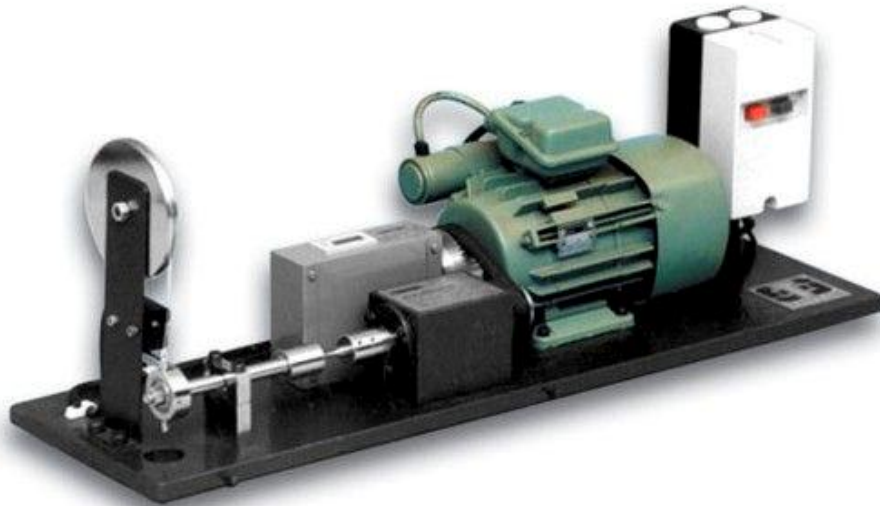

**Figure 9:** Fatigue testing machine in the laboratory



# Bending Test

## OBJECTIVES

- Students are required to study the principles of bend testing, practice their testing skills and interpreting the experimental results of the provided materials when failed under three-point bending.
- Investigate responses of metals when subjected to bending
- Determine parameters such as bend strength, yield strength in bending and elastic modulus.
- Students can interpret the obtained test data and select appropriate engineering materials for their intended uses in order to prevent creep failures.

## BEND OR FLEXURE TESTING

Bend or flexure testing is common in springs and brittle materials whose failure behaviours are linear such as concretes, stones, woods, plastics, glasses and ceramics. Other types of brittle materials such as powder metallurgy processed metals and materials are normally tested under a transverse flexure. Bend test is therefore suitable for evaluating strength of brittle materials where interpretation of tensile test result of the same material is difficult due to breaking of specimens around specimen gripping. The evaluation of the tensile result is therefore not valid since the failed areas are not included in the specimen gauge length.

Smooth rectangular specimens without notches are generally used for bend testing under three-point or four-point bend arrangements as shown in Figures 1a and 1b, respectively. Figure 2 illustrates three-point bending which is capable of 180° bend angle for welded materials.

مختبر مقاومة المواد

المرحلة الثانية

تجربة  
(5)

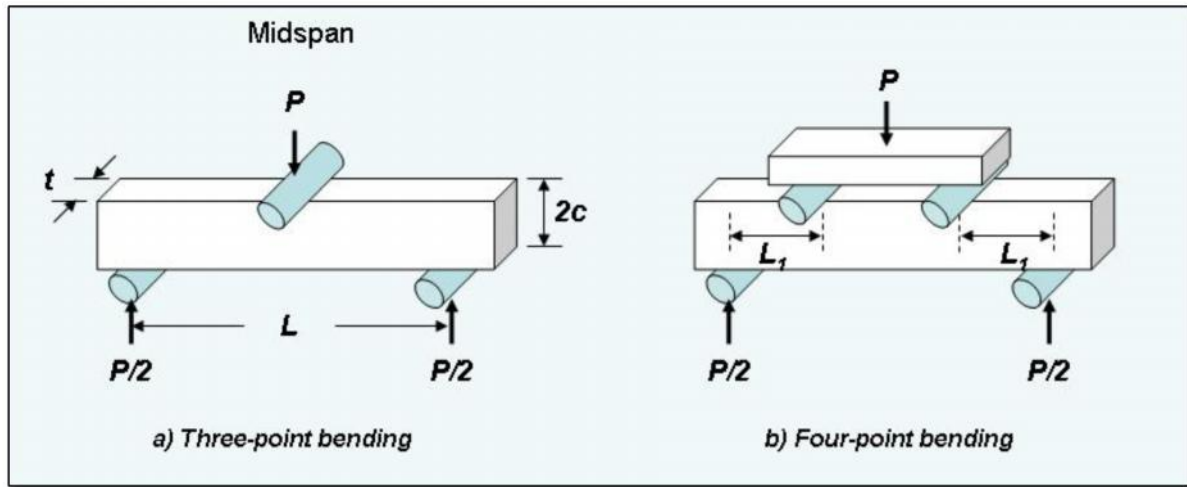

**Figure 1:** Bend testing of a rectangular bar under: (a) three-point bend and (b) four-point bend arrangements.

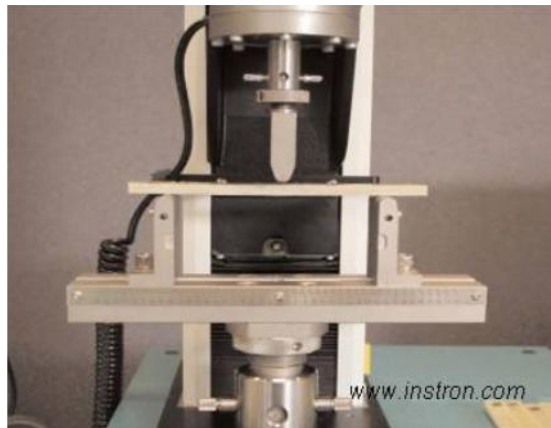

**Figure 2:** Example of bend testing under a three-point bend arrangement.

Considering a three point bend test of an elastic material, when the load  $P$  is applied at the midspan of specimen in an x-y plane, stress distribution across the specimen depth ( $h = 2c$ ) is demonstrated in Figure 3a. The stress is essentially zero at the neutral axis N-N. Stresses in the y-axis in the positive direction represent

tensile stresses whereas stresses in the negative direction represent compressive stresses. Within the elastic range, brittle materials show a linear relationship of load and deflection where yielding occurs on a thin layer of the specimen surface at the midspan. This in turn leads to crack initiation which finally proceeds to specimen failure. Ductile materials however provide load-deflection curves which deviate from a linear relationship before failure takes place as opposed to those of brittle materials previously mentioned. Furthermore, it is also difficult to determine the beginning of yielding in this case. The stress distribution of a ductile material after yielding is given in Figure 3b. Therefore, it can be seen that bend testing is *not suitable* for ductile materials due to difficulties in determining the yield point of the materials under bending and the obtained stress-strain curve in the elastic region may not be linear. The results obtained might not be validated. As a result, the bend test is therefore more appropriate for testing of brittle materials whose stress-strain curves show its linear elastic behaviour just before the materials fail.

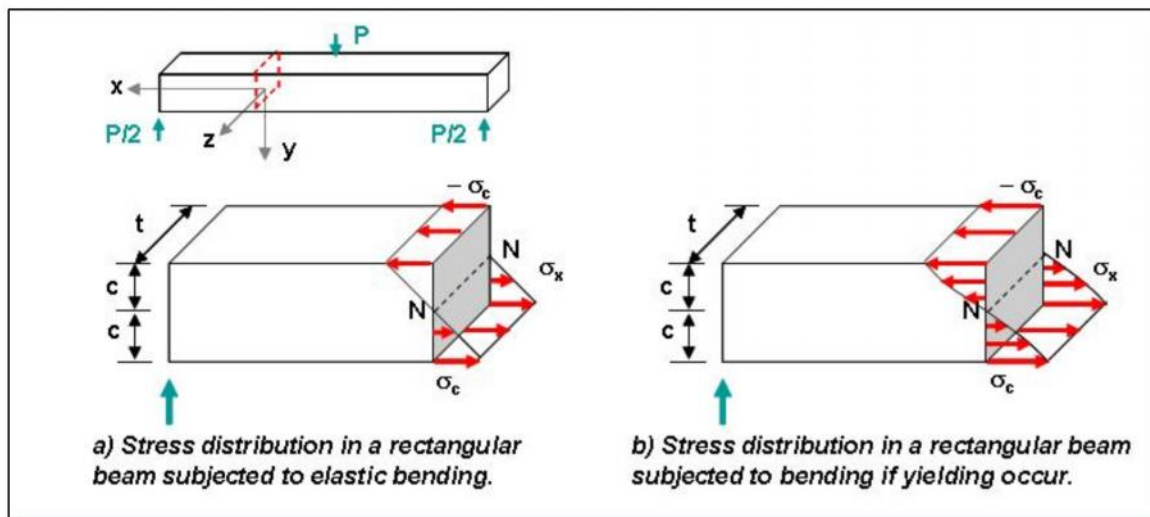

**Figure 3:** Stress distributions in a rectangular bar when a) elastically bended and b) after yielding.

For brittle materials having a linear stress-strain relation, the fracture stress ( $\sigma_f$ ) can be determined from the fracture stress in bending according to a linear elastic beam analysis as shown in equation 1

where  $M$  is the bending moment

$c$  is half of the specimen depth

$t$  is the thickness of the specimen

$I$  is the moment of inertia of the cross-sectional area

Under three-point bending in Figure 1a when the load  $P$  is applied at the midspan of a rectangular bar of a length  $L$  between the two rollers, the highest bending moment at the midspan is

where  $\sigma_{fb}$  is the calculated fracture stress

$P_f$  is the fracture load obtained from the bending test

The fracture stress in bending is called the *bend strength* or *flexure strength*, which is equivalent to the modulus of rupture in bending. The bend strength is slightly different from the fracture stress obtained from the tensile test if failure takes place further away from yielding. However, brittle materials possess higher strength in compression than in tension. The material failure under bending is therefore owing to the tensile stresses especially along the surface opposite to the load direction.

The determination of the yield strength ( $\sigma_y$ ) is carried out by replacing the load at yielding  $P_f$  in equation 4. Hence, eq. 4 will be,

The yielding load is determined at the definite yield point or at certain % offset. Hence, we now have the yield strength in equation 5. It should be noted that the yield strength obtained from the bend test is not different from the yield strength achieved from the tensile test. This is because the relationship between the load and the deflection remains linear at yielding.

The flexural strain  $\epsilon_f$  is calculated as

where  $v$  is the deflection of the beam.

Furthermore, from the experimental result, we can also obtain the elastic modulus of the material according to the linear-elastic analysis. The deflection of the center of beam can be expressed as

where the elastic modulus ( $E_B$ ) can be calculated from the slope of the load-deflection curve  $\frac{dP}{dv}$  in the linear region as follows

where  $m$  is the slope of the tangent to the straight-line portion of the load-deflection beam (Figure 4).

The elastic module achieved from the bend test are generally close to the elastic module obtained from tension and compression using the same material. However, there are several factors that might affect the elastic module, which are:

1. Elastic and plastic deformation at the rollers at the supports or the loading points might not be sufficiently small in comparison to the beam deflection.
2. If a short specimen is bend tested, deformation due to shear stress may take place, which are not ideal for the calculation according to the beam theory.
3. Materials might have different elastic moduli under bending, tension and compressive.

Therefore, the elastic module in bending should be identified avoid to any confusions for the interpretation of the mechanical behavior of the material.

#### **EXPERIMENTAL PROCEDURE**

- Measure the width and thickness of the specimen including the span length in the table provided for the calculation of the stress and elastic modulus. Mark on the locations where the load will be applied under three-point bending.
- Bend testing is carried out using a universal testing machine until failure takes place. Print out the load-deflection curve you have from the machine.

# Impact Test

## OBJECTIVES

The objective of the experiment is to test the ability of different types of specimens to withstand impacts using two procedures for impact tests, Izod and Charpy test methods.

## IMPACT TESTING MACHINE AND SPECIMENS

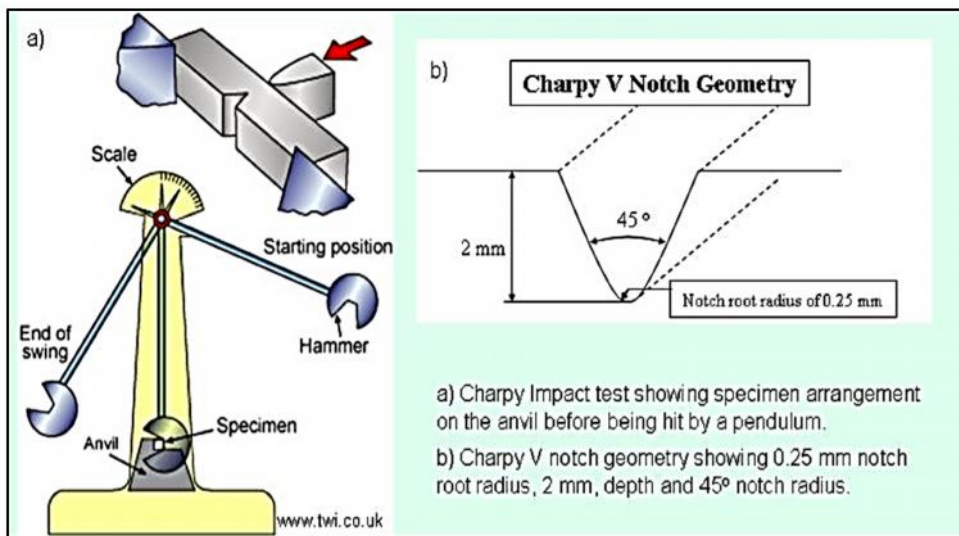

Figure 1: (a) Impact Testing Machine, (b) Notch Dimensions

## IMPACT TESTING THEORY

- Involves the sudden and dynamic application of the load. Parts such as shafts, bolts, anvils and dies are examples of items subjected to impact loading.
- **Impact test** is defined as the resistance of a material to rapidly sudden applied loads.
- **Toughness** is a property, which is capacity of a material to resist fracture, (crack propagation), when subjected to impact.

مختبر مقاومة المواد

المرحلة الثانية

تجربة  
(6)

- The machine measures the amount of energy absorbed by the specimen for the rupture in **joules** unit.
- The amount of energy absorbed can give an indication of the toughness of a material. It can classify the different types of materials into either brittle or ductile materials.

## **TWO BASIC TYPES OF IMPACT TESTING**

### **1. Charpy Impact Test**

- The specimen is supported as a simple beam with the load applied at the center.
- The position of latching tube is set to  $140^\circ$
- The specimen is supported horizontally from two sides

### **2. The Izod Test**

- The specimen is supported as a cantilever beam.
- The position of latching tube is set to  $90^\circ$
- The specimen is supported vertically from one side

Both Charpy and Izod impact testing use a swinging pendulum to apply the load. The difference in the Charpy and the Izod techniques is in the way that the specimens are supported in the apparatus machine. Using notched specimens the specimen is fractured at the notch.

## **HOW TO MEASURE ABSORBED ENERGY**

1. The load is applied as an impact from a hammer that is released from position  $h_1$ , as shown in Figure 2.
2. The pendulum with a knife-edge strikes and fractures the specimen at the notch.



3. The pendulum continues its swing, rising to a maximum height  $h_2$ ; which is lower than  $h_1$ .
4. The energy is calculated from the difference in initial and final heights of the swinging pendulum. Impact energy (toughness) from the test is related to the area under the total stress-strain curve.

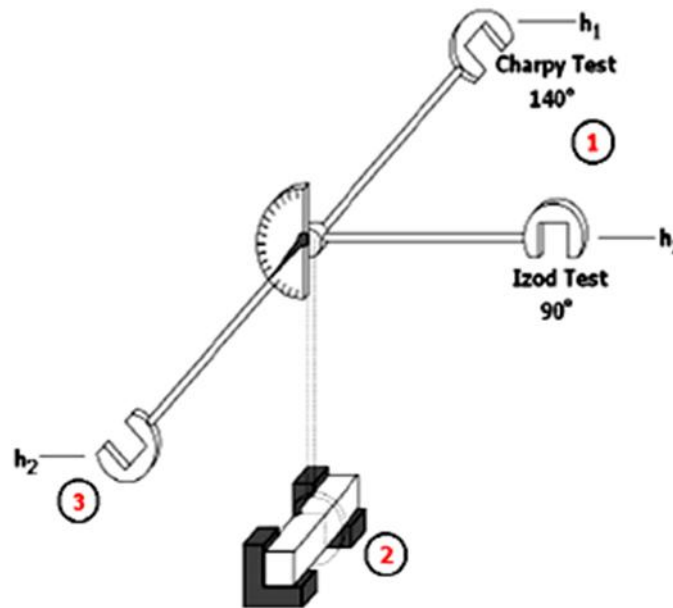

Figure 2: Measuring the absorbed energy.

### OPERATION

1. Select the test (Charpy/Izod)
2. Select and fit the respective striker in the hammer, first tighten the screws of the wedge and then of strikers
3. Fix the latching tube to corresponding position (for Charpy 140° position and for Izod 90° position).
4. Place a specimen on the support of the block.
5. Bring the striker (hammer) closely to specimen and tough it lightly with the specimen

6. Pointer when touched to its carrier should read 300 J line for Charpy and 170 J for Izod. Otherwise correct it by losing and tighten the screw of the pointer carrier.
7. Remove the specimen. Latch the hammer. Place the pointer as 300 J for Charpy and 170 J for Izod.
8. Release the hammer. Hold back the releasing lever.
9. The pointer will show the frictional losses. This reading should be less than 1.5 joules for Charpy and 0.8 for Izod
10. Thus the machine is ready for the tes

#### **CONDUCTING THE TEST:**

##### **A. Charpy Test:**

1. Place the specimen onto the support with notch facing backside of the striking direction
2. Using the setting gauge. Center the notch in between the anvils
3. Place the pointer to read 300 J. latch the hammer
4. Release the hammer. The pointer will indicate the amount of energy consumed by the specimen

##### **B. Izod Test**

1. Place the specimen onto the support with notch facing forwards the direction of striker of the striking direction
2. Using the setting gauge, center the notch to the reference level
3. Face the pointer to read 170 J. latch the hammer
4. Release the hammer. The pointer will indicate the amount of energy consumed by the specimen for its rupture

**FRACTURE SURFACE**

- (a) Highly ductile fracture: specimen neck down to a point
- (b) Moderator ductile fracture: rough plastic deformation
- (c) Brittle fracture without any plastic deformation